



**Table 1 — U-Factors (BTU/hrft<sup>2</sup> °F) and R-Values (hrft<sup>2</sup> °F/BTU) of Concrete Masonry Walls<sup>A</sup>**

Nominal Wythe Thickness in. (mm)	Concrete Density pcf	Standard CMU Cores Empty		100% Solid Grouted <sup>B</sup>	
		U	R	U	R
8 in. (203 mm)	85	0.402	2.5	0.525	1.9
	95	0.427	2.3	0.559	1.8
	105	0.452	2.2	0.592	1.7
	115	0.479	2.1	0.623	1.6
	125	0.507	2.0	0.654	1.5
	135	0.537	1.9	0.684	1.5
12 in. (305 mm)	85	0.390	2.6	0.441	2.3
	95	0.411	2.4	0.466	2.1
	105	0.433	2.3	0.490	2.0
	115	0.455	2.2	0.515	1.9
	125	0.478	2.1	0.539	1.9
	135	0.503	2.0	0.564	1.8

Table 1 Source: Abbreviated NCMA TEK 6-2B.



**Table 2 — U-Factors (BTU/hrft<sup>2</sup> °F) and R-Values (hrft<sup>2</sup> °F/BTU) of Omni Block Walls<sup>A</sup>**

Nominal Wythe Thickness in. (mm)	Concrete Density pcf	Stretcher Unit Cores Empty <sup>C</sup>		Cores With EPS Inserts <sup>D,E</sup>	
		U	R	U	R
8 in. (203 mm)	85	0.123	8.2	0.047	21.2
	95	0.133	7.5	0.048	20.6
	105	0.139	7.2	0.049	20.2
	115	0.146	6.8	0.050	19.9
	125	0.153	6.5	0.051	19.6
	135	0.161	6.2	0.052	19.3
12 in. (305 mm)	85	0.102	9.8	0.032	31.0
	95	0.110	9.1	0.033	30.3
	105	0.115	8.7	0.033	29.9
	115	0.121	8.3	0.034	29.5
	125	0.126	7.9	0.034	29.2
	135	0.133	7.5	0.035	28.8

Table 2 Source: Tom Norris, Architect (ICC Certified).



Expires 9.30.18

**Table 3 — Thermal Resistance of EPS Foam Insulation**

EPS Type	Minimum Density (pcf) <sup>F</sup>	R-Value Per Inch of Thickness (F° · ft <sup>2</sup> · h/BTU)
II	135	4.00

Table 3 Source: ICC ESR — 1498 per ASTM C 578.

**Disclaimer:** The information presented in this report/analysis is to assist architects, designers, professional builders, and professional engineers when utilizing the Omni Block Insulated Concrete Block System. While the material is presented in good faith and believed to be reliable, it does not constitute a part of, or terms and conditions of sale. No engineering data, design information or other material contained herein shall be deemed to constitute a warranty, expressed or implied, that said information is correct or that the products described are fit for a particular purpose of design application.

**Prevailing Code:** The information presented in this report/analysis is not intended to supersede any building code.

- A (hrft<sup>2</sup>°F/BTU) (0.176) = m<sup>2</sup>/K/W. Mortar joints are 3/8" (9.5 mm) thick, with face shell mortar bedding. Unit dimensions based on *Standard Specification for Loadbearing Concrete Masonry Units*, ASTM C 90. Surface air films are included.
- B Grout density is 140 pcf (2,243 kg/m<sup>3</sup>). Lightweight grouts will provide higher R-values and may be used.
- C 8 inch unit has an additional face shell and reduced cross-web conductance. Resulting formula: (hrft<sup>2</sup>°F/BTU)(1.50) + (hrft<sup>2</sup>°F/BTU)(1.76).  
12 inch unit has two additional face shells and reduced cross-web conductance. Resulting formula: (hrft<sup>2</sup>°F/BTU)(2.00) + (hrft<sup>2</sup>°F/BTU)(1.772).
- D Values apply when all cores are filled completely.
- E Average continuous insulation correction factor is 10% less than total insert R-value. Some table values are the same due to rounding.
- F pcf = 16.02 kg/m<sup>3</sup>, 1°F ft<sup>2</sup>/hr/BTU = 0.176m<sup>2</sup>/K/W, 1°F = 1.8°C + 32.

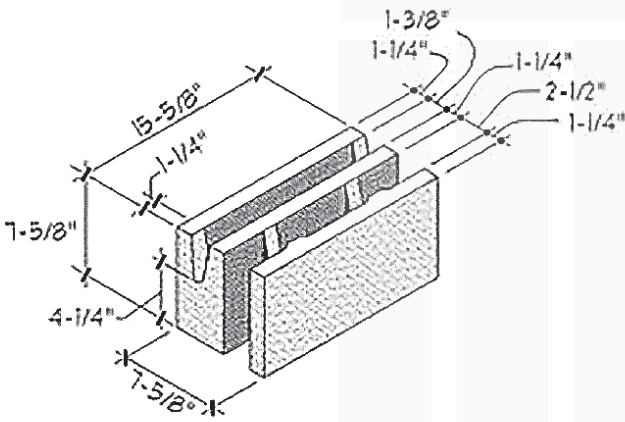

**STRETCHER - 8 X 8 X 16**

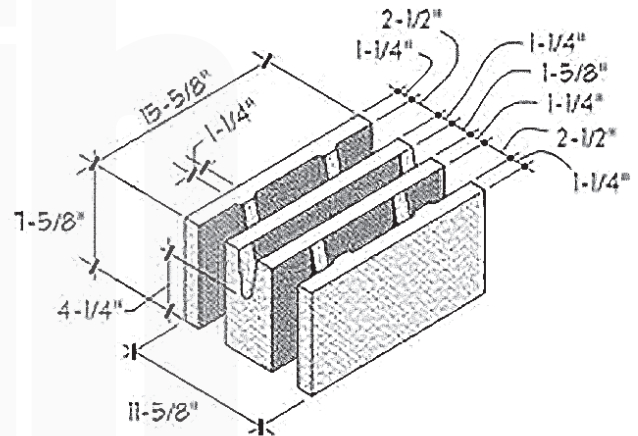

**STRETCHER - 12 X 8 X 16**

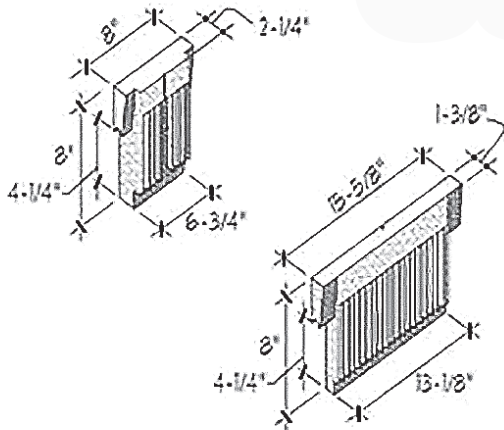

**INSULATION INSERTS**