

The Westbrook Concrete Block Co., Inc.

P.O. Box 700
Westbrook, CT 06498
Phone 860-399-6201

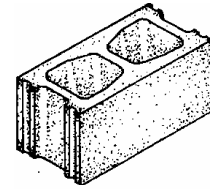

ARCHITECTURAL SPECIFICATION LIGHTWEIGHT CONCRETE MASONRY UNITS

GENERAL

Comply with the referenced standards and other requirements indicated below for each form of concrete masonry unit required. Lightweight concrete masonry units shall be as manufactured by **The Westbrook Concrete Block Co., Inc. – P.O. Box 700– Westbrook, CT 06498.**

Provide special shapes including starter and soap courses where required, and for lintels, bull nose corners, jambs, sash, control joints, and other special conditions as indicated.

PERFORMANCE

Concrete Block: Provide units complying with characteristics indicated for Grade, Type, face size and exposed face. Provide Lightweight Units with a density of less than 105 pcf. Unless otherwise indicated.

A.S.T.M. C-90 (latest revision) - Type I, Moisture-controlled.

Lightweight Units: Lightweight aggregate shall be 100% expanded shale produced by the rotary kiln process complying with A.S.T.M. C-331 with a gradation of No. 4 to 0, Table 1 of A.S.T.M. C-331, aggregate as manufactured by the Norlite Corporation. Dry net weight of less than 90 pcf, blended with normal weight aggregate conforming to A.S.T.M. C-33

For all fire rated assemblies provide concrete masonry units conforming to **Underwriters Laboratories Inc. UL 618 and design numbers: U901, U904, U906, U910, U912, U913 and U914.**

DIMENSIONS

Size: Manufacturer's standard units as follows: 16" long x 8" High (15 5/8" x 7 5/8" actual) x thickness as indicated.

APPEARANCE

All units shall be sound and free of cracks or other defects that would interfere with the proper placement of the unit or would significantly impair the strength or permanence of the construction. Minor crack incidental to the usual method of manufacture or minor chipping resulting from customary methods of handling in shipment and delivery are not grounds for rejection. Five percent of a shipment containing chips not larger than 1 inch in any dimension, or cracks not wider than 0.02 in. and not longer than 25% of the normal height of the unit is permitted.

(over)

Additional Options Where Appropriate

- A. Scored Units - Units shall contain one vertical square edged score $3/8'' \times 3/8''$ located in the center of the exposed face.

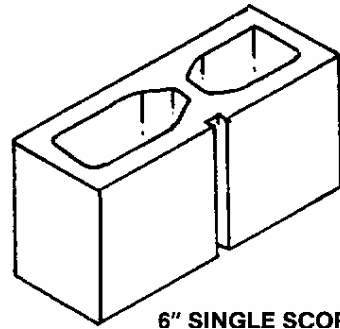
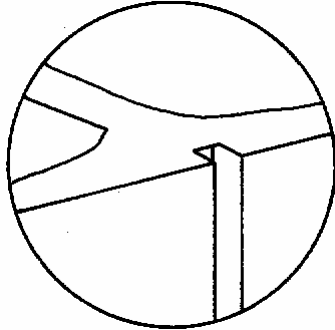

6" SINGLE SCORE

- B. Units shall have _____ vertical scores, each square edged $3/8'' \times 3/8''$ at equal spacing across the exposed face.
- C. Where a fire resistance rating is required provide units conforming to the appropriate **Underwriters Laboratories Design Number**.
- D. Insulation: Inserts shall be installed in the cores of the blocks at the block manufacturer's plant. The inserts shall be Korfil® as manufactured by Concrete Block Insulation Systems, Inc. (CBIS)
- E. Units shall be manufactured with an integral water repellent system by a qualified block producer.
- F. Provide bull nose units at all corners and door and window sills, and window sills.

Available in 4", 6", 8", 10", and 12" wall widths

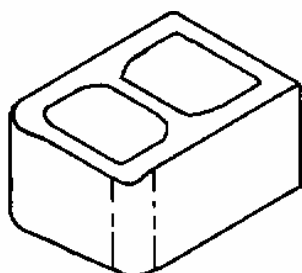

12" DOUBLE

bullnose Sill

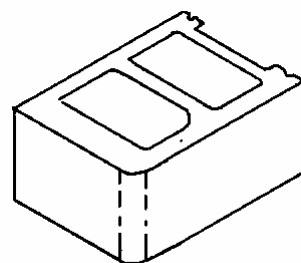
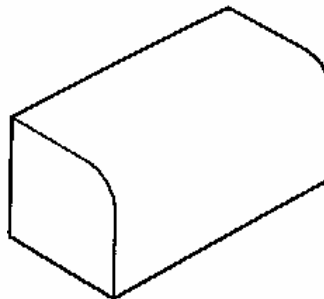

12" SINGLE